



MANTIS[®]
CRANES

Crane Rental Association of Canada

2013

2013 CRAC Conference





TADANO MANTIS History

1979: Spandek launches Mantis telescopic boom crawler cranes



TADANO MANTIS History

1983: Launched Mantis 5012 (25 Ton)

1985: Crane Only Manufacturing Begins

TADANO MANTIS History

1986: Added Special Projects





TADANO MANTIS History

Late 1980's: Special Projects



TADANO MANTIS History

1989: Railroad Cranes Introduced



TADANO MANTIS History

1989: Railroad Cranes Introduced



TADANO MANTIS History

1990's: Telecrawler Line Expanded To 7 Models (18 Ton-70 Ton)



TADANO MANTIS History

*Early 2000's: New Models Added
7 Models (30 Ton-100 Ton)*



TADANO MANTIS History

2008: Tadano Acquires Mantis



TADANO MANTIS History

2012: Tadano's LMI System (AML-C) Added to Mantis Cranes



Facilities

Corporate Offices in Franklin, TN



Facilities

Manufacturing in Richlands, VA

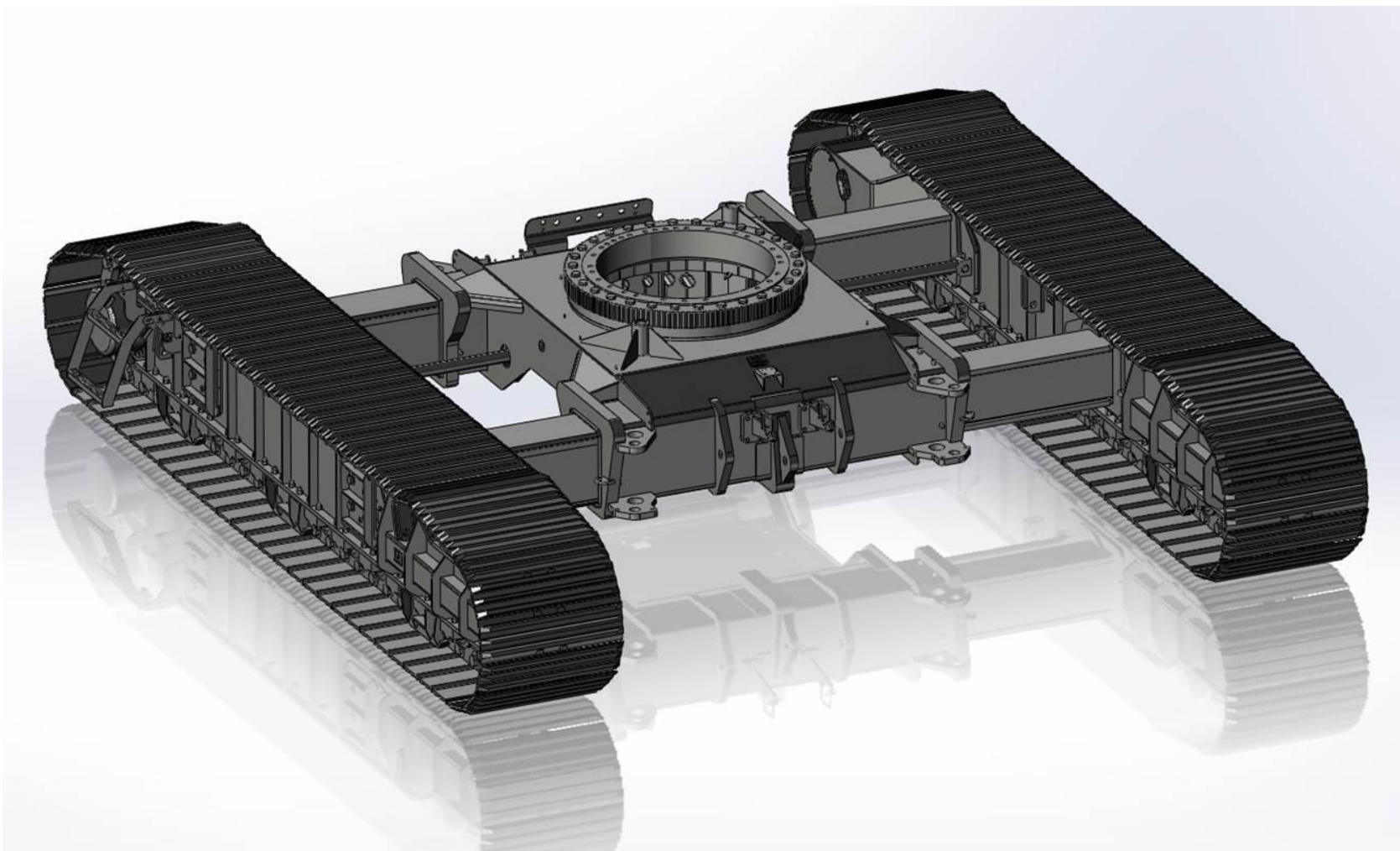

Purpose Built Design: Undercarriage

Heavy Duty Undercarriage



Purpose Built Design: Undercarriage

Pick and Carry Full Load Chart



Purpose Built Design: Undercarriage

Pick and Carry Full Load Chart

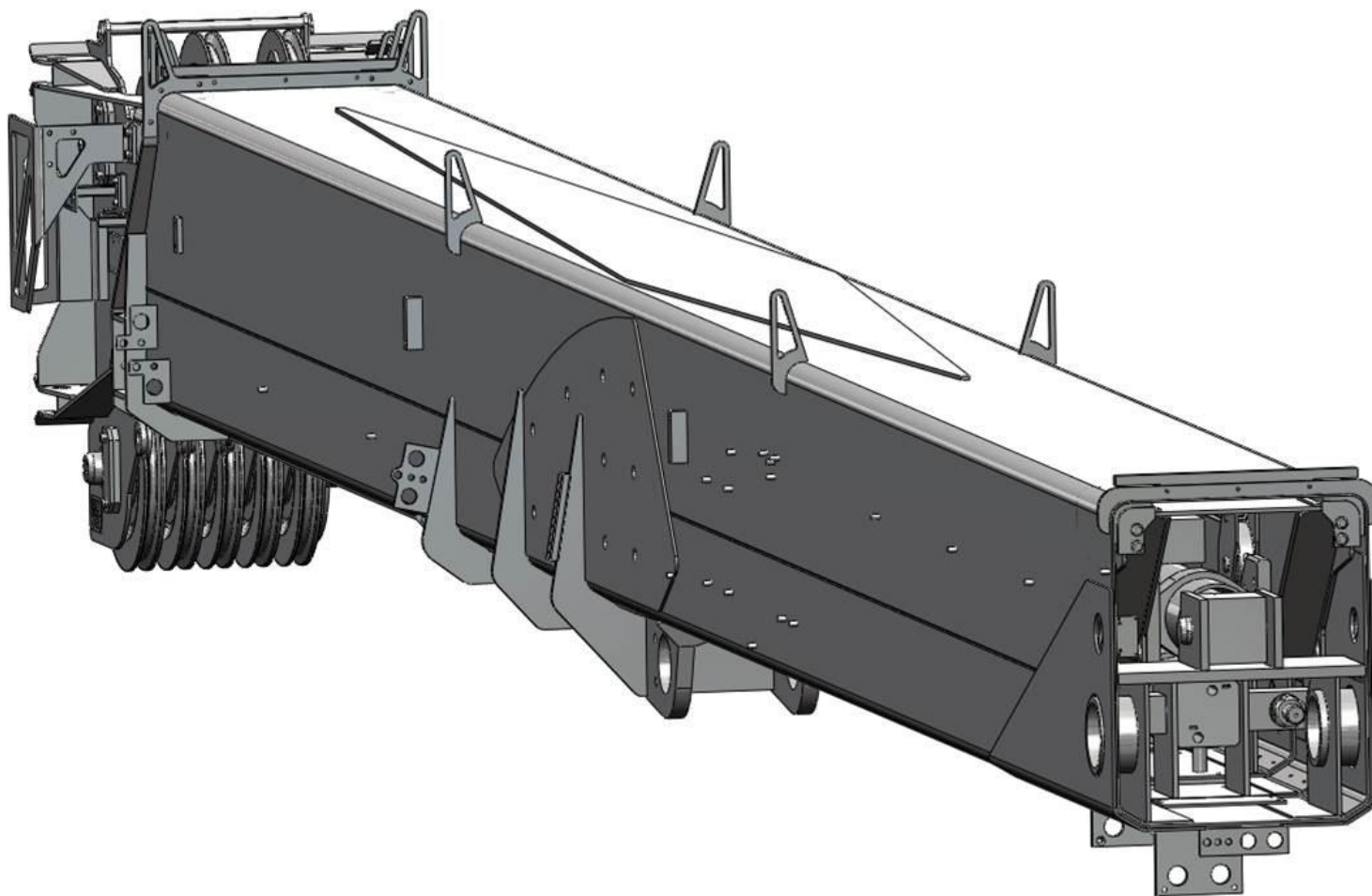

Purpose Built Design: Boom

Heavy Duty Boom



Purpose Built Design: Boom

Heavy Duty Boom



Purpose Built Design: Boom

Telescope Boom With Load On The Hook



Purpose Built Design: Boom

Approved For Use With Foundation Attachments



Purpose Built Design: Track Frame & Drive

High Tractive Effort



Purpose Built Design: Track Frame & Drive

Low Ground Pressure



Purpose Built Design: Track Frame & Drive

Gradeability

TADANO MANTIS Models

6010	30 Ton
6010LP	30 Ton, Low Profile
8012	40 Ton
9010	45 Ton
10010MX	50 Ton
15010	77 Ton
20010	100 Ton
30011	150 Ton, Rerailer
200RS	100 Ton, Rail Service



TADANO MANTIS 6010

Load Rating	30 Ton
Main Boom Length	32'8"-80'
Extension & Jib	20' & 20'
Horsepower	173
Gradeability	53%
Ground Pressure	6.5 PSI
Operating Weight	62,820 LB
Counterweight	11,500 LB (1 pc)



TADANO MANTIS 6010LP

Load Rating	30 Ton
Main Boom Length	32'8"-80'
Extension & Jib	20' & 20'
Horsepower	173
Gradeability	53%
Ground Pressure	6.5 PSI
Operating Weight	62,820 LB
Counterweight	11,500 LB (1 pc)



TADANO MANTIS 8012

Load Rating	40 Ton
Main Boom Length	39'-90'
Extension & Jib	30' & 20'
Horsepower	260
Gradeability	56%
Ground Pressure	6.2 PSI
Operating Weight	86,904 LB
Counterweight	10,000 LB (1 pc)



TADANO MANTIS 9010

Load Rating	45 Ton
Main Boom Length	34'-105'
Extension & Jib	30' & 20'
Horsepower	260
Gradeability	68%
Ground Pressure	6.7 PSI
Operating Weight	93,904 LB
Counterweight	15,000 LB (1 pc)



TADANO MANTIS 10010MX

Load Rating	50 Ton
Main Boom Length	37'6"-111'6"
Extension & Jib	30' & 20'
Horsepower	260
Gradeability	57%
Ground Pressure	7.4 PSI
Operating Weight	103,640 LB
Counterweight	20,000 LB (1pc)



TADANO MANTIS 15010

Load Rating	77 Ton
Main Boom Length	37'6"-111'6"
Extension & Jib	30' & 20'
Horsepower	260
Gradeability	68%
Ground Pressure	9.3 PSI
Operating Weight	137,554 LB
Counterweight	35,000 LB (2 pcs)



TADANO MANTIS 20010

Load Rating	100 Ton
Main Boom Length	42'-128'
Extension & Jib	35' & 25'
Horsepower	375
Gradeability	60%
Ground Pressure	11.4 PSI
Operating Weight	202,300 LB
Counterweight	35,240 LB (2 pcs)





TADANO MANTIS 30011

Train Rerailer



TADANO MANTIS 200RS

Rail Service Crane

Mantis Options

- Auger
- Pole Claw
- Hydraulic Tool Circuit



Mantis Options

- Work Platform



Mantis Advantage: Power Transmission Work

Access any site; Multi-task



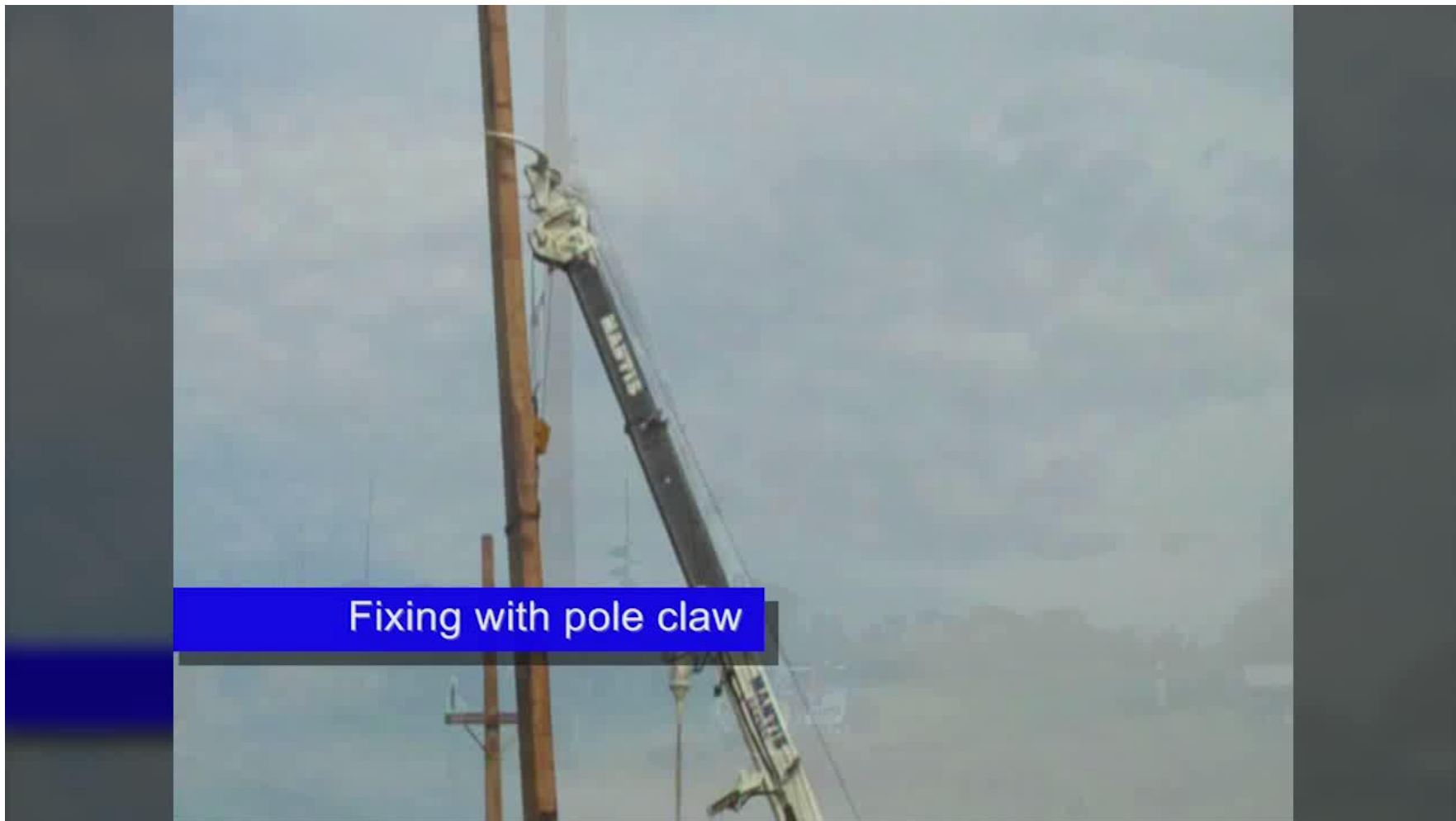

Fixing with pole claw

Mantis Advantage: Power Transmission Work

Mantis Options: Lead Ready Package

Remote Operated Kicker, Pile Gate, and Hammer Trip





Mantis Options: Lead Ready Package

Console Mounted Remote, Quick Connect Fittings



Mantis Advantage: Foundation Work

Quickly Convert From Lift Crane To Piling Machine

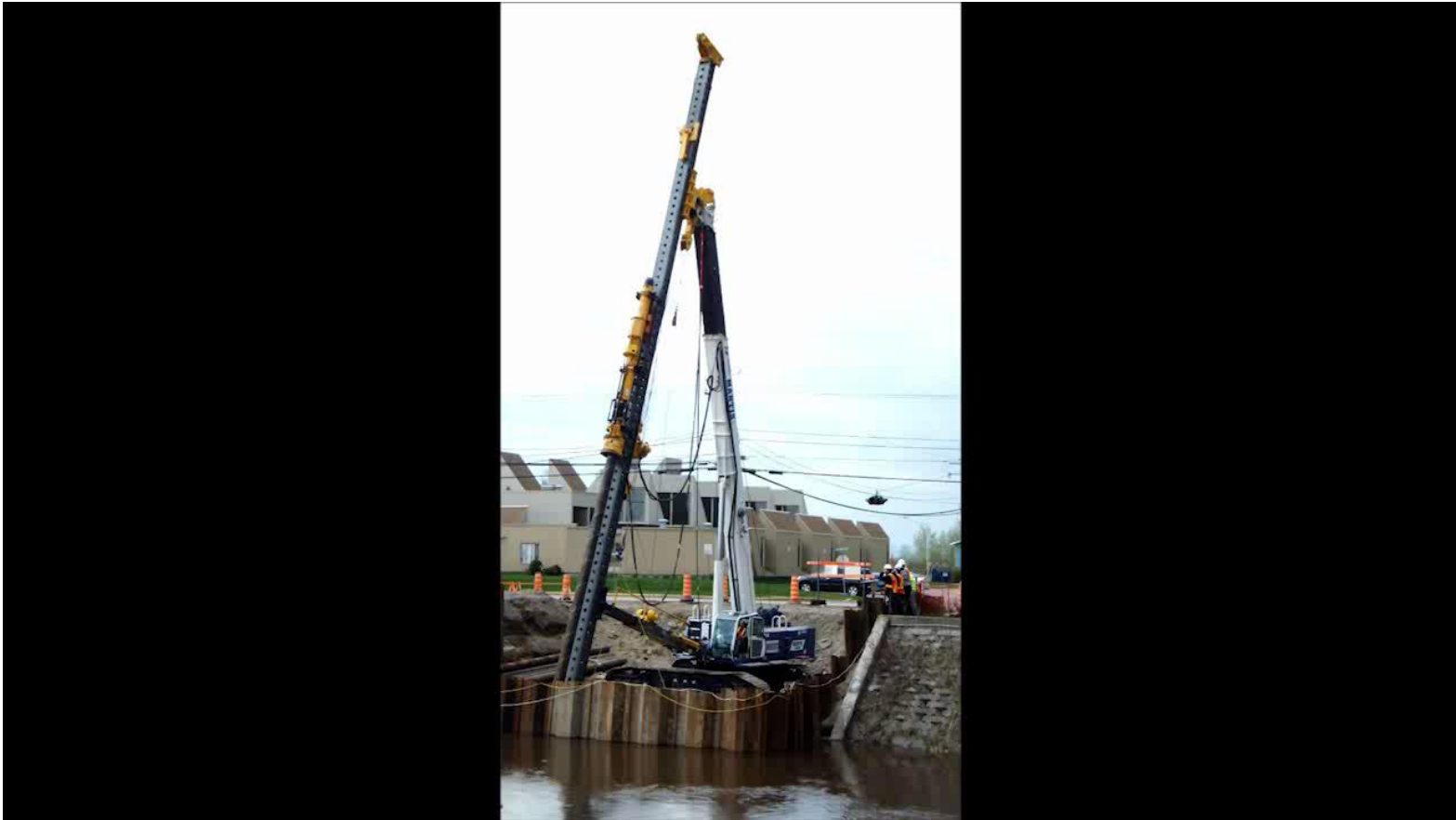

Mantis Advantage: Foundation Work

Quickly Convert From Lift Crane To Piling Machine

Mantis Advantages vs. RT Cranes



**Quick Repositioning or Pick
& Carry Full Capacity**



Re-deploy Outriggers or Decrease Capacity



Mantis Advantages vs. RT & Truck Cranes

Confined Areas With No Room For Outriggers



Mantis Advantage vs. RT Cranes

Gradeability; Pick & Carry Full Load Chart

Mantis Application: Wind Towers



Mantis Application: Bridges & Infrastructure



Mantis Application: Power Transmission



Mantis Application: Foundations



Mantis Application: Tank Building



DVDs Available Include:

- PowerPoint Presentation
- Load Charts
- Brochures
- Application Videos





MANTIS[®]
CRANES

Thank You!

Any Questions or Comments?

